

## Warning



Every person involved with the installation, operation and maintenance of this system has to:

- be qualified
- follow the instructions of this manual

Only use the supplied DAP audio adapter.

## Description

The AMM-401 is a 4 channel active mixer in a very compact housing. An ideal audio tool for sound engineers or musicians that often need to improvise. It can also be helpful to extend an USB audio interface with some extra inputs. It is a mixer in the most simplistic way with 4 volume controls for 2 stereo and 2 mono inputs. The mono inputs can be used for instrument microphones, but also with line level sources, using the PAD switch.

- 2 stereo inputs
- 2 mono inputs
- Balanced outputs
- Selectable line/instrument mono inputs

## Overview

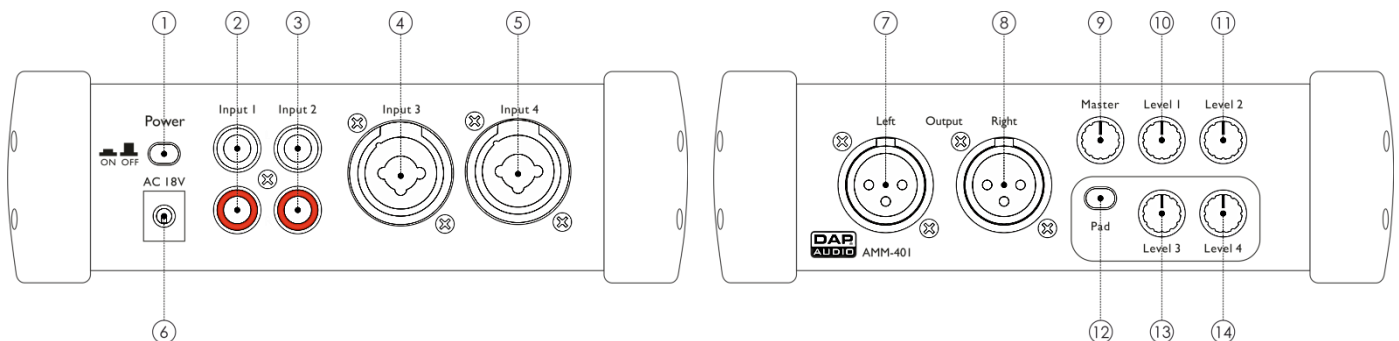

- ① Power on/off switch
- ② Input 1, Unbalanced stereo RCA pin jacks.
- ③ Input 2, Unbalanced stereo RCA pin jacks.
- ④ Input 3, Balanced combo-type input for connecting low impedance microphones.
- ⑤ Input 4, Balanced combo-type input for connecting low impedance microphones.
- ⑥ Power adapter connector
- ⑦ Balanced XLR output connector (L)
- ⑧ Balanced XLR output connector (R)
- ⑨ Controls the output level of the main mix.
- ⑩ The volume control adjusts the level of the channel 01 signal.
- ⑪ The volume control adjusts the level of the channel 02 signal.
- ⑫ Pad function
- ⑬ The volume control adjusts the level of the channel 03 signal.
- ⑭ The volume control adjusts the level of the channel 04 signal.

# Connection Example

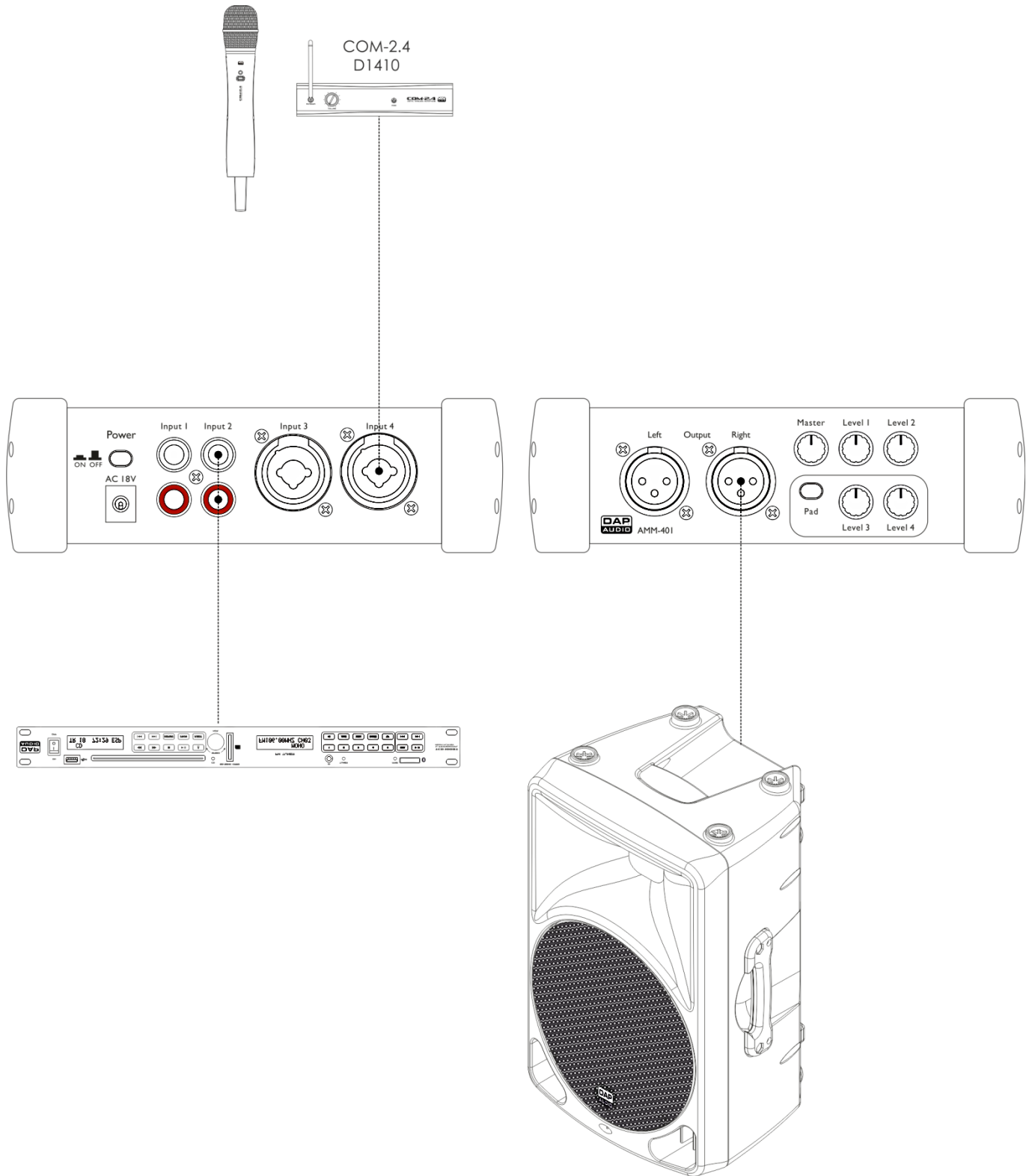

## Dimensions

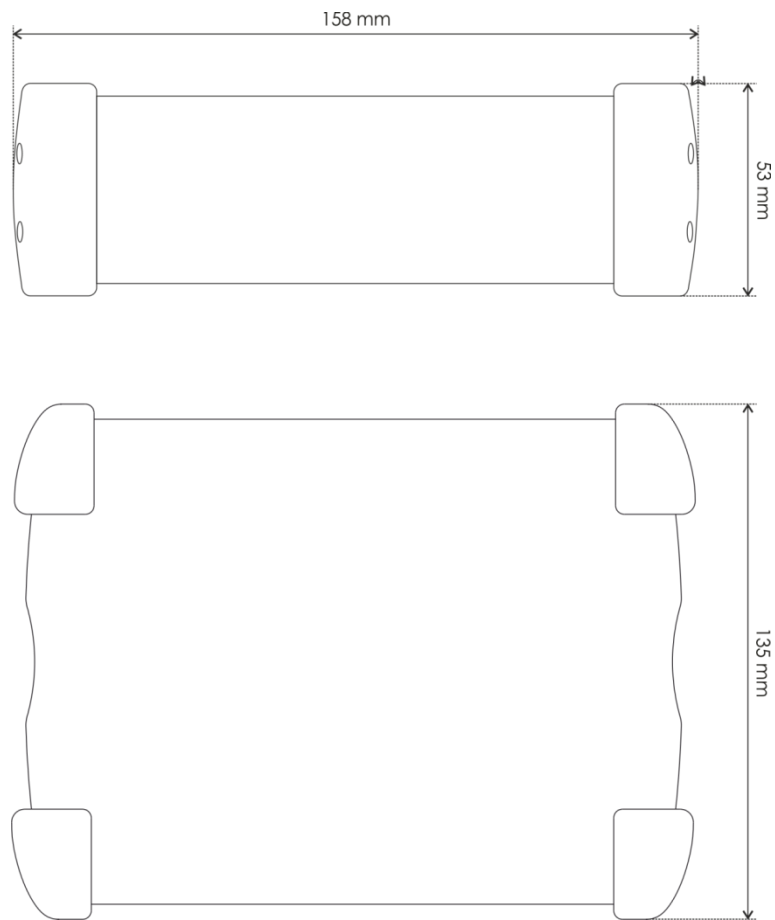

## Specifications

Frequency Response:	20Hz-20KHz
Inputs:	RCA, XLR/Jack Combo
Outputs:	XLR male
Input Impedance line:	1M $\Omega$
Input Impedance:	50 k $\Omega$
Output Impedance:	12 K $\Omega$
Power supply:	18V AC (adapter included)
Dimensions:	53x158x135 mm (HxWxD)
Weight:	0,7 Kg

